

motor information:

winding connection	star-Y		delta-Δ		Unit
speed	3500	8500	7500	15000	r/min
Torque	122.8	50.6	57.3	28.7	Nm
Power	45	45	45	45	kW
Voltage	320	380	380	380	V
Current	105	96	58	51	A
Frequency	175	425	375	750	Hz

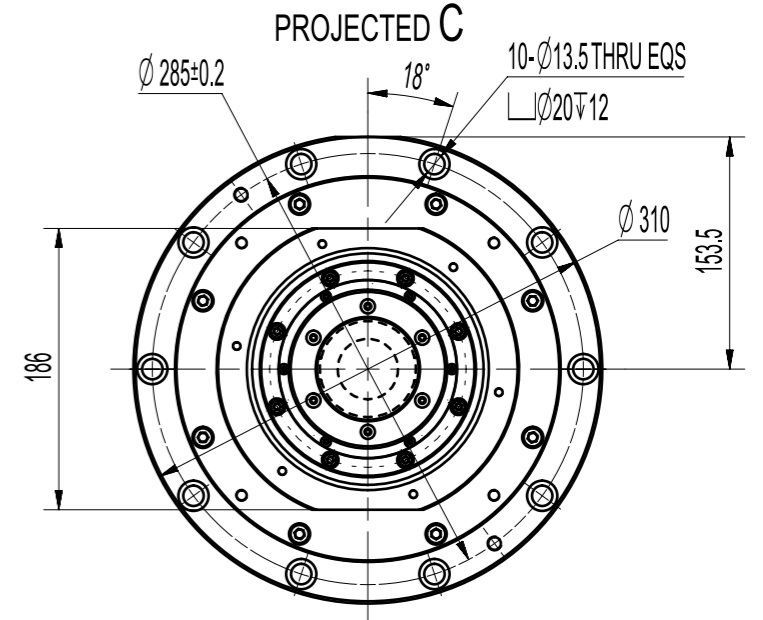
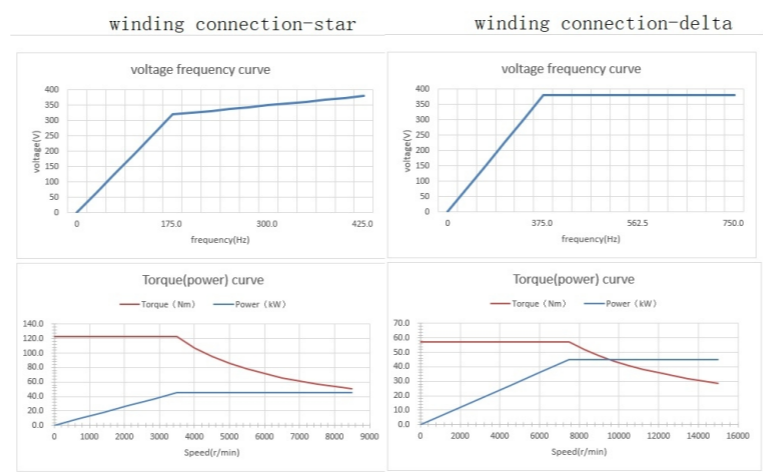

Technical information:

Speed	15000 r/min
Rotation	right and left
Operating position	horizontal-vertical
Lubrication	Grease
Cooling	Water
Front seal	Protecting air flow, 1-1.5bar, Filter 5µm
Front bearing	Hybrid-Ceramic bearing Ø70
Interface	SK40 DIN69871/69872
Encoder	SECONA Z=256,m=0.4,1vpp
Clamping force	8500N
Hydraulic pressure	unclamping:80-85bar,clamping10-15 bar
Force for tool change	15000N
Hydraulic oil volume	unclamping 40ml,clamping 30ml
Power	45 kW @ 3500-15000 r/min
Center coolant	0-40 bar, Filter 50 µm
Temperature sensor for motor	PT100

未注尺寸公差		-	主轴确认图		数量	材料	硬度	备注
注:孔取(+),轴取(-)			件号	名称				
尺寸/mm								
大于	至	公差						
-	6	±0.05				洛阳速锋主轴 科技有限公司	260XDJ15G45	
6	30	±0.10						
30	120	±0.15				设计		比例
120	250	±0.25				校对		重量
250	500	±0.35				标准化审核		1:5
500	1000	±0.45				工艺会签		
1000	1600	±0.55				审核		
1600	2000	±0.65	更改号	签字	日期	批准		